



Owner's Manual

Sprayer Nurse Trailer
1000 Gallon
Model # NGX1000T

Dealer: _____
Contact: _____
Phone: _____
Model #: _____
Serial #: _____

Manufactured by PBZ LLC
A Paul B Zimmerman Inc. Company
www.CropCareEquipment.com

Table of Contents

Identification of Machine	3
Introduction	3
Safety	4-8
Safety Alert Symbol	4
Signal Words.....	4
Hazards.....	5
Preparation for Use	5-6
General Guidelines.....	5
Chemical Warnings	5
Pump Precautions	5
Preparation for Use	6
During Use	6
Clearing Blockages and Cleaning.....	7
Transporting the Unit.....	7
Maintenance and Adjustment	7
After Use / Storage.....	7
Safety Signs	8
Operation	9-16
Operating Instructions	9-12
Pre-start Instructions.....	9
Preparing the Unit.....	9
Priming the Pump	9
Operation of all Functions.....	10-12
Using the Quick-Fill System	10
Using the Transfer Line	11
Operating the Chemical Induction System.....	11
Operating the Rear Watering Bar.....	12
Following Operation.....	12
Instructions for Clearing Blockages and Cleaning.....	13
Troubleshooting	14-15
Pumps (Suction & Pressure).....	14-15
Chemical Induction.....	15
Plumbing Diagram.....	16
Maintenance and Adjustments.....	17-23
Maintenance Schedules.....	17
Maintenance Procedures.....	17-19
Every Use	17
Every Season	17-18
Preparing the Unit for Winterizing	18
Winterizing the Unit	18-19
Junction Box, Electric Brake Battery Case/Tester & Breakaway Switch	20
Wiring Diagram	21
Wiring.....	22
Maintenance Materials.....	23
Adjustments.....	23
Storage	24
Specifications.....	24
Transportation.....	24
CropCare® Limited Warranty	25
Warranty Coverage	25
Warranty is Void if.....	25
Getting Warranty Service.....	25
Ordering Parts.....	25
Parts List & Breakdowns.....	25

Identification of Machine

- Model#: NGX1000T
- The serial number plate is located on the outer face of the hitch rail on the driver's side of the unit.

Introduction

Please read and understand this manual and its instructions and warnings completely before operating the unit.

- This unit is designed to only be used in an agricultural environment for support of commodity spraying applications.
- Read and understand the chemical manufacturer's labels, warnings, and instructions.
- Know and fulfill all state pesticide applicator license requirements.
- Familiarize yourself and other operators with the unit's components and how all parts are operated.
- Contact / Sources for help interpreting the owners manual.
- Read and follow ALL of the chemical manufacturer's labels, warnings, and instructions about chemical usage! A material safety data sheet (MSDS) should be provided by the chemical manufacturer. CropCare® is not liable for misuse or mishandling of chemicals before spraying, during spraying, and after spraying.

Safety Alert Symbol

-The safety alert symbol for safety signs & decals that contain one of the three signal words (DANGER, WARNING, & CAUTION) will appear as shown in figure 1.



Figure 1: Safety Alert Symbol

Signal Words

-There are three signal words; DANGER, WARNING, and CAUTION. The signal words bring attention to the existence and relative seriousness of a hazard.

- **DANGER:** The signal word DANGER indicates an imminently hazardous situation which, if not avoided, will result in death or serious injury
- **WARNING:** The signal word WARNING indicates a potentially hazardous situation which, if not avoided, could result in death or serious injury.
- **CAUTION:** The signal word CAUTION indicates a potentially hazardous situation which, if not avoided, may result in minor or moderate injury.

-Additional Signal Words.

- **NOTE:** The signal word NOTE provides information on operator safety and operator tips.
- **IMPORTANT:** The signal word IMPORTANT indicates a recommended action or a restriction that will ensure correct equipment operation and performance.

Hazards



Preparation for Use



1.) General Guidelines

Every year many unnecessary accidents occur due to improper equipment handling and a disregard for safety precautions. The equipment operator can avoid accidents by observing the precautions in this section.

- The best defense against accidents is a careful and responsible operator.
- The operator should be a responsible adult. Do not allow persons to operate this unit until they have displayed a thorough understanding of unit safety precautions and operational use!
- Never attempt to operate this unit when under the influence of alcohol or drugs.
- ALL replacement parts need to be an OEM part or an aftermarket equivalent
- If there is any portion of this manual that you do not fully understand, please contact the original retailer.

2.) Chemical Warnings

- All operators must also fulfill state pesticide applicator license requirements!
- Be aware of the chemical warning decal on the unit tank (Figure 1).
- Read and follow chemical manufacturer's labels, warnings, and instructions! A material safety data sheet (MSDS) should be provided by the chemical manufacturer.

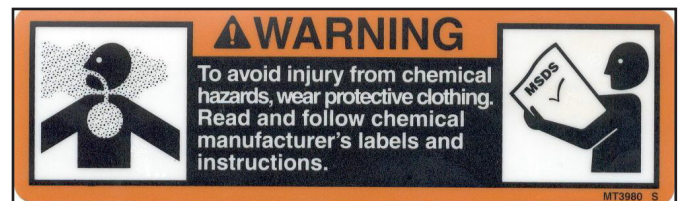

Figure 1: Chemical Warning Decal (DEMT3980)

- To avoid injury from chemical hazards, wear the proper protective clothing. Each chemical manufacturer's clothing requirements are listed under the "Personal Protective Equipment (PPE) section in the chemical instructions.

3.) Pump Precautions

NOTE: See pump owner/operator's manual for more details on pump precautions.

- In refueling engine, observe all safety precautions for the handling of the fuel.
- WARNING: Never refuel the engine while it is running. Care should be exercised so that no fuel is spilled on a hot engine. Always allow engine to cool at least two minutes before refueling.
- WARNING: Never operate the engine in an explosive atmosphere, near combustible materials, or where there is insufficient ventilation for engine exhaust fumes.
- IMPORTANT: Do not run the pump dry. Always fill the pump body with the liquid to be pumped before starting the pump.
- Never pump flammable or explosive fluids such as gasoline, fuel oil, kerosene, etc.
- Never pump liquids at temperatures higher than the recommended maximum temperature (140°F / 60°C) Do not exceed this temperature.
- Before servicing your pump, shut off the engine, release all pressure, and drain all liquids.
- CAUTION: Always remove spark plug or spark plug wire from engine before working on pump unit to prevent accidental starting.

4.) Preparation for Use

- Be aware of the location of all the safety and warning decals. Always replace any decals that are illegible or are missing.
- Carefully study and understand this owner's manual.
- Be aware of the owner's manual decal (Figure 2 & 3).
- Before adding chemicals, have all operators practice operating the unit (clean water only) and its attachments until all operators are completely capable of safe operation.
- Do not wear loose-fitting clothing which may catch in moving parts.
- Visually inspect the unit for any worn parts, loose bolts, or other visible problems, and make the necessary repairs. See the maintenance section.
- All unit maintenance should be performed with the unit unhooked from the tractor and clean of any harmful chemicals.
- To avoid injury from chemical hazards, always wear the proper personal protective equipment (PPE).
- Make sure the area is clear of any people or obstructions before using the unit.

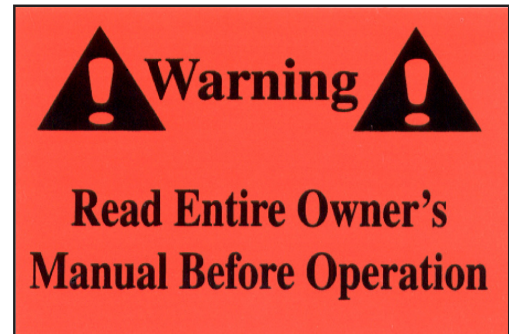

Figure 2: Owner's Manual Decal (DE39)



Figure 3: Read Owner's Manual Warning (DE115)

During Use

- Always be aware of bystanders, particularly children! Always look before moving the unit. Bystanders should never be allowed near the unit during operation.
- No passengers are allowed on or in the tractor or unit at any time.
- Only disconnect unit on a solid level surface. The tank must be empty.
- Be aware of dangerous terrain such as holes, slopes, drop-offs, banks, rocks, and hidden hazards. Operate the tractor and unit up and down slopes, not across.
- When operating on inclines, it is especially important that your tractor is equipped with Roll Over Protection System (ROPS).
- Never leave running equipment unattended!
- Remember that accidents can even happen to seasoned operators. Always take your time and follow all safety instructions.



Clearing Blockages and Cleaning



- Wear chemical resistant gloves and eye protection at all times while clearing blockages and cleaning the unit.
 - Before clearing blockages and cleaning, make sure the unit and rinse tank is drained entirely.
 - Make sure unit is parked on a solid level surface before clearing blockages and cleaning the unit.
 - Do not stand on the unit while clearing blockages and cleaning the unit.
 - CAUTION: Be sure to THOROUGHLY wash any skin that has been exposed to chemicals after clearing blockages and cleaning the unit.
-



Transporting the Unit



- When transporting the unit on public roads, always follow state and local regulations regarding safety and transportation requirements. Use the necessary lights and slow moving vehicle (SMV) emblems.
 - Never exceed the tow vehicle's load and/or tow ratings.
 - Check lighting before traveling.
 - Check the unit's braking system to ensure proper function. (Junction Box, Electric Brake Battery Case/Tester & Breakaway Switch, page 19)
 - Make sure SMV sign is not blocked or bent.
 - Always connect safety chains and trailer breakaway cable to towing vehicle.
-



Maintenance and Adjustment



- Wear chemical resistant gloves and eye protection at all times while performing adjustments and maintenance.
 - Make sure unit is parked on a solid level surface before performing adjustments and maintenance.
 - Make sure unit is clear of all chemical residue in the location where the adjustments are being made.
 - CAUTION: Be sure to THOROUGHLY wash any skin that has been exposed to chemicals after performing adjustments and maintenance.
-



After Use / Storage



- Following operation, stop the towing unit, set the brakes, shut off the engine, and remove the ignition key.
 - Completely rinse the entire unit and all of its components of all chemical residue after every use.
 - Dispose of rinsate in accordance with chemical application guidelines.
 - Park the unit on a hard level surface, away from all human and livestock activity.
 - Do not permit children to play on or around unit.
-

Safety Signs

- Signs and decals used to indicate safe practices while preparing, transporting, and operating the unit.
- Make sure that they are not obstructed by dirt or chemical residue. Clean as necessary.
- Replacements can be ordered from a CropCare® Dealer.

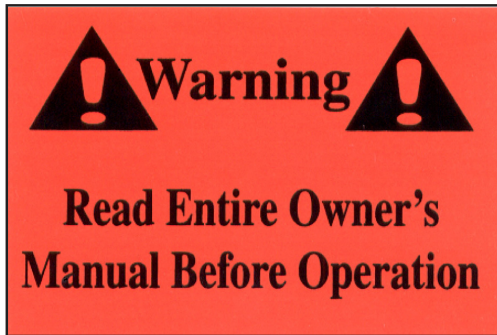

Figure 1: Owner's Manual Decal (DE39)

- Located on the main tank of the unit

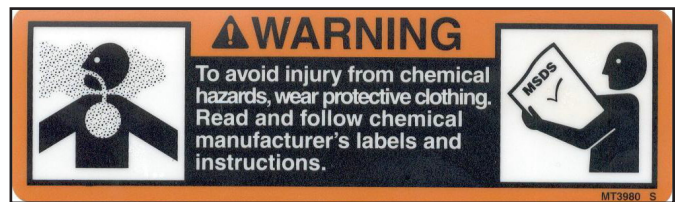

Figure 2: Chemical Warning Decal (DEMT3980)

- Located on the main tank of the unit.



Figure 3: Read Owner's Manual Warning (DE115)

- Located at components that require operator adjustment.
- See Owner's Manual for information on components requiring operator adjustment.

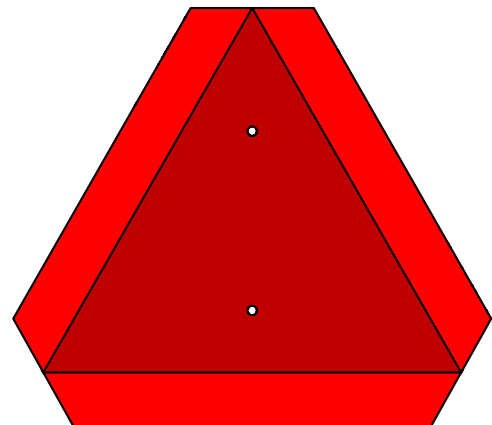

Figure 4: Slow Moving Vehicle Sign (SMV)

- Located on the rear of the unit.
- Indicates that this is a vehicle or implement that is traveling slower than the rate of traffic.



Figure 5: Open Tank Lid when Pumping Fluid into or out of Tank

- Located at tank lid and pump.

Operating Instructions

Pre-start Instructions

1.) Preparing the Unit

Before operating the unit, it is important that you read this entire manual and know all safety precautions. Always take your time and be alert when operating your sprayer nurse trailer. This will allow you to safely make use of this equipment without accident or interruption.

1. To avoid injury from chemical hazards, wear the proper protective clothing. Each chemical manufacturer's clothing requirements are listed under the "Personal Protective Equipment (PPE) section in the chemical's instructions.
2. Check status of the battery for the electric brakes (See Junction Box, Electric Brake Battery Case/Tester & Breakaway Switch, page 19.)
3. Fill engine crankcase with proper oil as specified by the engine manufacturer. (See engine owner's manual for details.)
4. Fill engine fuel tank with clean, fresh, unleaded grade automotive gasoline.
5. **IMPORTANT:** Fill the pump body with liquid before starting.
6. **IMPORTANT:** To prevent damage to the tank, open the sealed main tank lid when pumping fluid into or out of the tank.
7. Fill the unit's tank with clean fresh water in order to test the unit. The unit can be filled through the tank opening, or using the pump when equipped with the optional quick fill (See Using the Quick Fill System, page 10). Testing the unit before operation will give you a chance to familiarize yourself with all of the components and to test for any leaks or problems.
8. Open the suction valve located underneath the tank (b) (Figure 2, page 10).
9. Open bypass valve (c) (Figure 3, page 10) located at the front of the tank.
10. Start the engine to engage the pump. (**IMPORTANT:** Make sure the pump body is full of liquid before starting.)
11. Inspect the unit for any leaks or problems. If you have any questions or concerns please contact your local CropCare[®] dealer.

2.) Priming the Pump

1. To prime the pump, fill the pump body with liquid.
2. **IMPORTANT:** To prevent damage to the tank, open the sealed main tank lid when pumping fluid into or out of the tank.
3. Open the main suction line valve located below the tank (b) (Figure 2, page 10), then fully open the bypass valve (c) (Figure 3, page 10).
4. Start the engine to engage the pump and let it operate at approximately 75% of its maximum recommended RPM.
5. If the pump does not prime, check suction line filters and hoses for leaks, debris, or clogs. (Refer to the Clearing Blockages and Cleaning Section (page 13), or the Troubleshooting section, pages 14-15). Refer to pump owners manual for troubleshooting instructions specific to the pump.

Operation of all Functions

1.) Using the Quick-Fill System (If Equipped)

1. **IMPORTANT:** To prevent damage to the tank, open the sealed main tank lid when pumping fluid into or out of the tank.
2. Remove the dust cap (a) on the quick coupler and connect the transfer hose to the coupler (Figure 1). Open the valve on the nurse tank/transfer hose.
3. Open the tank valve (b) (Figure 2) underneath the unit tank.
4. Open the bypass valve (c) (Figure 3) in the front of the tank.
5. Open the valve (d) at the quick coupler (Figure 1).
6. Start the engine to engage the transfer pump (**IMPORTANT:** Make sure pump body is filled with liquid before starting the engine). When the tank approaches the desired level close the quick fill valve (a) (Figure 1) and turn off the transfer pump. Close the valve on the nurse tank/transfer hose.
7. Disconnect the transfer hose from the quick coupler and replace the dust cap.

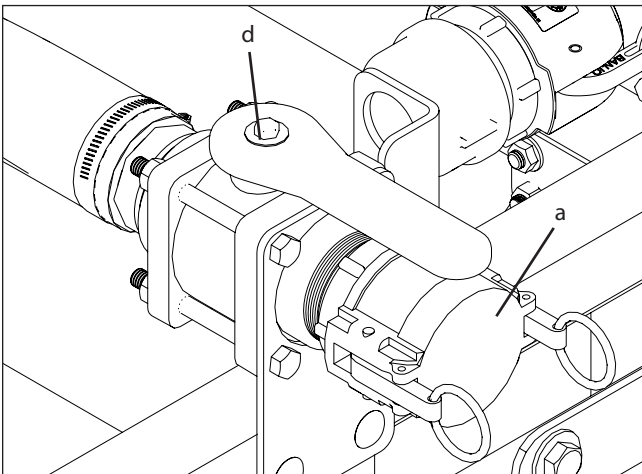

Figure 1: Quick Fill Valve & Dust Cap

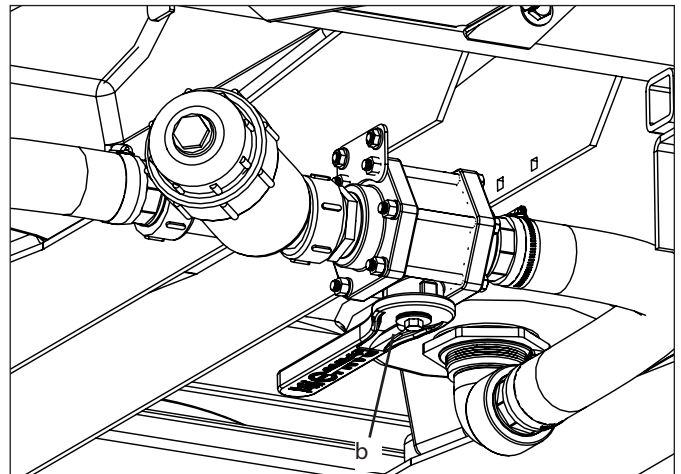

Figure 2: Tank Valve

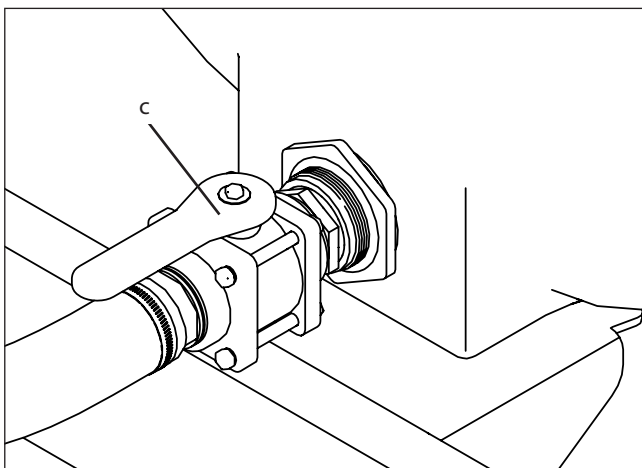

Figure 3: Bypass Valve

Operation

2.) Using the Transfer Line

1. **IMPORTANT:** To prevent damage to the tank, open the sealed main tank lid when pumping fluid into or out of the tank.
2. With transfer pump engaged, uncouple the transfer hose from its storage mount (a) (Figure 4) (Make sure that the valve (b) is still closed).
3. Couple the coupler to the quick coupling on the sprayer that you are filling, and open the valve (b). **NOTE:** To increase speed of filling, partially close the bypass valve (c) (Figure 3, page 10).
4. If equipped with chemical induction on this unit refer to the instructions for operating the chemical induction system.
5. When finished filling the sprayer tank, close the transfer

valve (b) and uncouple the transfer line. Reconnect to the storage mount coupling.

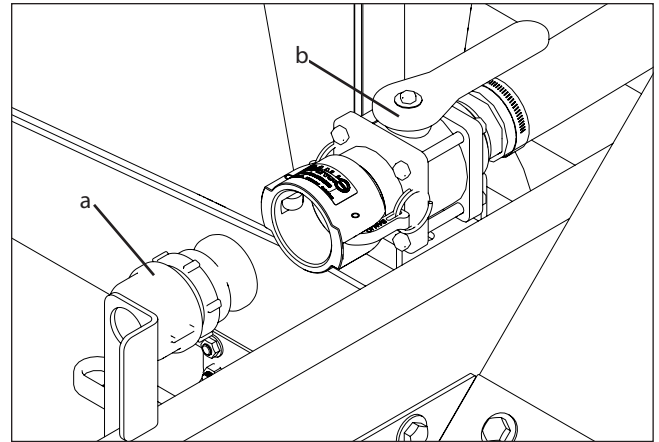

Figure 4: Transfer Line

3.) Operating the Chemical Induction System (If Equipped)

1. Before using the chemical induction system, the unit tank must be filled to at least 25% full of its total capacity.
2. **IMPORTANT:** To prevent damage to the tank, open the sealed main tank lid when pumping fluid into or out of the tank.
3. The tank suction valve (b) must be opened (Figure 2, page 10).
4. The transfer line must be hooked up to the sprayer, and the valve (b) (Figure 4) opened.
5. The pump must be running and primed (see Priming the Pump section, page 9).
6. Partially close the suction valve (a) (approximately 1/3) as shown (Figure 5).
7. **IMPORTANT:** Close the bypass valve (f) (Figure 5) (if equipped) to prevent chemical from returning to the tank.
8. Open the induction tank valve (b), as shown (Figure 5), to induct the chemicals. Lift the lid (c) and pour the chemicals into the induction tank (d) (Figure 5).
9. To incorporate soluble powder or granular chemicals, open the induction rinse valve (e) (Figure 5) and slowly pour the chemical into induction tank (d) (Figure 5).
10. If the chemical begins to vortex in the induction tank, slowly close the induction valve (b) (Figure 5) until the chemical begins to be inducted properly.
11. After all of the chemicals are inducted, rinse the induction tank and line with clean water.

12. When the chemical induction tank is properly rinsed, close the induction valve (b) (Figure 5) and fully open the suction valve (a) (Figure 5).

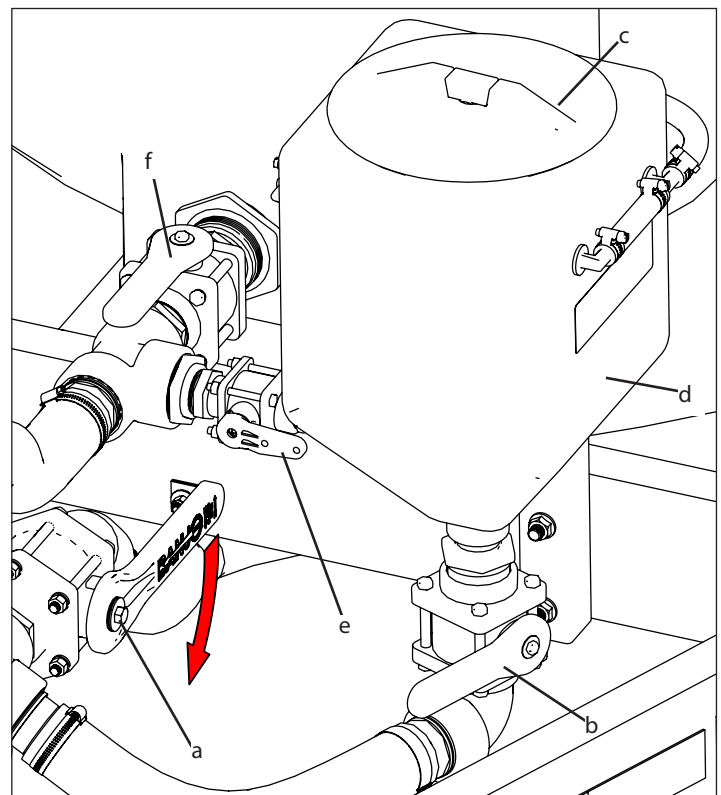

Figure 5: Chemical Induction System

Operation

4.) Operating the Rear Watering Bar (If Equipped)

1. With pump engaged, uncouple the transfer hose from its storage mount (a) (Figure 4, page 11) (Make sure that the valve (b) is still closed).
2. Couple the coupler to the quick coupling (a) (Figure 6) on the rear watering bar, and open the valve (b).
3. When finished spraying, close the transfer valve (b) and uncouple the transfer line. Reconnect to the storage mount coupling.

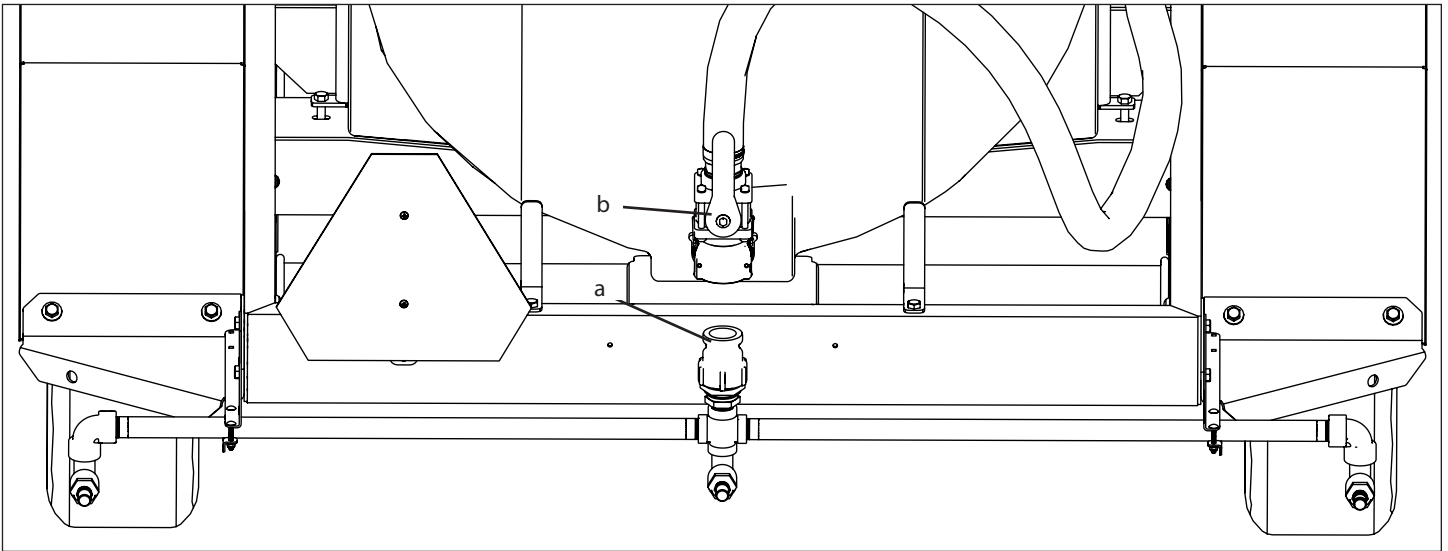

Figure 6: Rear Watering Bar

5.) Following Operation

1. Before transporting the unit, make sure that the safety chains and breakaway cable are attached to the tow vehicle.
2. Before storing the unit ensure that the unit's tank, pump, and chemical induction system are completely rinsed out. This can be done by manually rinsing the unit's tank and running the clean water through the unit's pump and chemical induction system until the system is completely rinsed out. All rinsate must be sprayed on the field as recommended by the chemical manufacturer.
3. Excess water can be drained by removing the bowl of the in-line suction filter (a) located below the tank (Figure 7).
4. Always flush out the pump at the end of operation if the liquid being pumped may leave a solid or sticky residue in the pump. If this is not done, damage to the pump may result.
5. If freezing conditions are expected, make sure that the pump body is drained. If the unit is going to be stored over winter follow instructions from the Winterizing section.

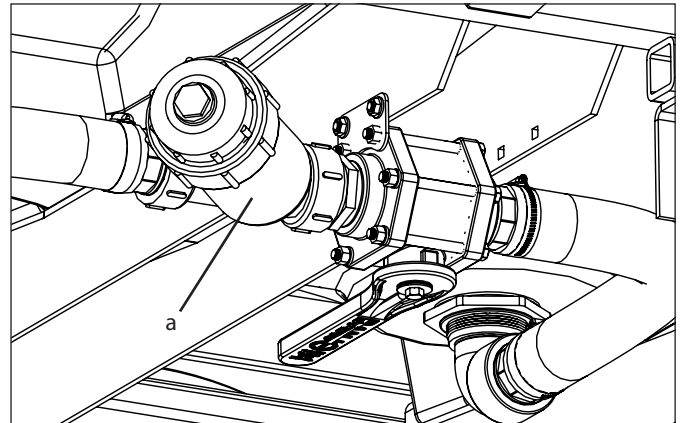

Figure 7: In-line Suction Filter

Instructions for Clearing Blockages and Cleaning

1.) Clearing Blockages

-If the unit encounters issues with low spray volume, it may be due to a blockage in one or some of the plumbing components. Some common blockage issues that can occur, along with how to resolve the issue, are detailed in the text below. If any fittings, filters, or plumbing parts are damaged, contact your authorized CropCare® dealer for replacement parts.

NOTE:

- The best way to avoid blockages is to thoroughly rinse all plumbing components after each use.
 - ALWAYS follow the chemical manufacturer's disposal instructions when disposing clean out rinsate and chemical build up.
 - Wear all necessary PPE recommended by the chemical manufacturer (i.e. chemical resistant gloves, safety goggles, chemical resistant suit) when clearing out blockages and handling chemical build up.
- Sometimes hose fittings and small diameter hoses can accumulate build up if the unit is not properly rinsed after use. After locating a clogged fitting or hose, remove it and try to dislodge blockage. Once blockage is removed, reinstall the hose or hose fitting.
 - This unit is outfitted with a suction strainer in the line from the tank. This filter can become clogged over time from foreign debris or chemical build up. Remove the strainer from the filter and rinse thoroughly with water until the screen on the strainer is clean and reinstall.
 - Tanks have sumps and low points that over time can accumulate debris and chemical build up. If debris or chemical build up is spotted in the tank, use a Shop-Vac to clean out debris in tank. If the chemical build up is hardened in the sump and fittings, disassemble affected fittings and clean out hardened debris or chemical build up. Be sure to clean out Shop-Vac of all chemical build up after clearing blockages.

2.) Cleaning Unit

NOTE:

- ALWAYS follow the chemical manufacturer's disposal instructions when cleaning unit.
 - Be familiar with local legislation regarding disposal of chemicals and decontamination methods.
 - Wear all necessary PPE recommended by the chemical manufacturer according to chemical manufacturer (i.e. chemical resistant gloves, safety goggles, chemical resistant suit) when cleaning unit.
- It is good practice to clean the unit, inside and out, after every use. Keeping the unit clean helps prolong the life of the unit and unit components.
 - Select a soak away area where the cleaning rinsate can be safely be disposed. Most pesticide washings can be washed off on a soak away. A soak away is an area that is currently not being used for crops. That soak away CANNOT directly runoff into wells, springs, streams, water courses, ditches, or sewers.
 - A pressure washer can be used to wash down the unit. Do not directly spray high pressure water onto electrical components, spray tips, or any other moisture or pressure sensitive components.

Troubleshooting

-Information for fault diagnosis and remedy of problems in operation.

Pumps (Suction & Pressure)

Issue	Probable Cause	Solution
Loss of Operating Pressure	Clogged suction filter	Remove strainer from filter bowl, and clean or replace it.
	Air leak on suction side of the unit	Locate the leak and fix it.
	a. Defective O-ring or seal	Replace the O-ring or seal.
	b. Hole in hose	Patch the hole, or replace the hose if necessary.
	c. Cracked plastic fitting	Replace fitting.
	Clogged or restricted suction line hose or fitting	Remove hose or fitting and unclog it, or replace if necessary.
	In-line filters plugged	Remove strainer from filter bowl, and clean or replace it.
	Low fluid level in tank	Add fluid as necessary to finish spraying.
Pump is slow to prime	Defective pump seals	Replace seals. (See Pump Owner's Manual for details.)
	Material lodged in the pump	Disassemble pump and remove material. (See Pump Owner's Manual for details.)
	Clogged suction filter	Remove strainer from filter bowl, and clean or replace it.
	Clogged or restricted suction line hose or fitting	Remove hose or fitting and unclog it, or replace if necessary.
	Air leak on suction side of the unit	Locate the leak and fix it.
	a. Defective O-ring or seal	Replace the O-ring or seal.
	b. Hole in hose	Patch the hole, or replace the hose if necessary.
Pump leaking fluid	c. Cracked plastic fitting	Replace fitting.
	Defective pump seals	Replace seals. (See Pump Owner's Manual for details.)
Loss of spray pressure (Optional Rear Watering Bar)	Pump housing or cover is cracked	Replace components or pump. (See Pump Owner's Manual for replacement parts.)
	Clogging suction filter	Remove strainer from filter bowl, and clean or replace it.
	Air leak on suction side of the unit	Locate the leak and fix it.
	a. Defective O-ring or seal	Replace the O-ring or seal.
	b. Hole in hose	Patch the hole, or replace the hose if necessary.
	c. Cracked plastic fitting	Replace fitting.

Operation

Pumps (Suction & Pressure)

Issue	Probable Cause	Solution
Ball valves turn with difficulty	Ball and ball seal are dry due to spray material	Replace ball and seal, or replace the valve.
	Ball and ball seat are damaged	Replace valve.
	Displaced O-ring or material restricting the ball	Disassemble valve and replace O-ring.
Pressure loss after refilling	Clogging suction filter	Remove strainer from filter bowl, and clean or replace it.
	Closed suction valve	Open suction valve.
	Material lodged in the pump	Disassemble pump and remove material. (See Pump Owner's Manual for details.)
Can't get all of the fluids out of the tank	Unit is not level	Move unit to level location, or adjust 3PT arms to level 3PT hitch unit.
	Air leak on suction side of the unit	Locate the leak and fix it.
	a. Defective O-ring or seal	Replace the O-ring or seal.
	b. Hole in hose	Patch the hole, or replace the hose if necessary.
	c. Cracked plastic fitting	Replace fitting.
Pump does not prime	Pump body is empty of fluid	Fill pump body with fluid.
	Closed suction valve	Open suction valve.
	Damaged impeller	Replace the impeller and seals. (See Pump Owner's Manual for replacement parts.)
	Outlet port in the tank is plugged or restricted	Unclog the outlet. (See the "Clearing Blockages and Cleaning" sections.)

Chemical Induction

Issue	Probable Cause	Solution
Tank back fills when valve is opened or drains slowly	Pump is running too slow	Increase the engine rpms.
	Air leak on suction side of the unit	Locate the leak and fix it.
	a. Defective O-ring or seal	Replace the O-ring or seal.
	b. Hole in hose	Patch the hole, or replace the hose if necessary.
	c. Cracked plastic fitting	Replace fitting.

Plumbing Diagrams

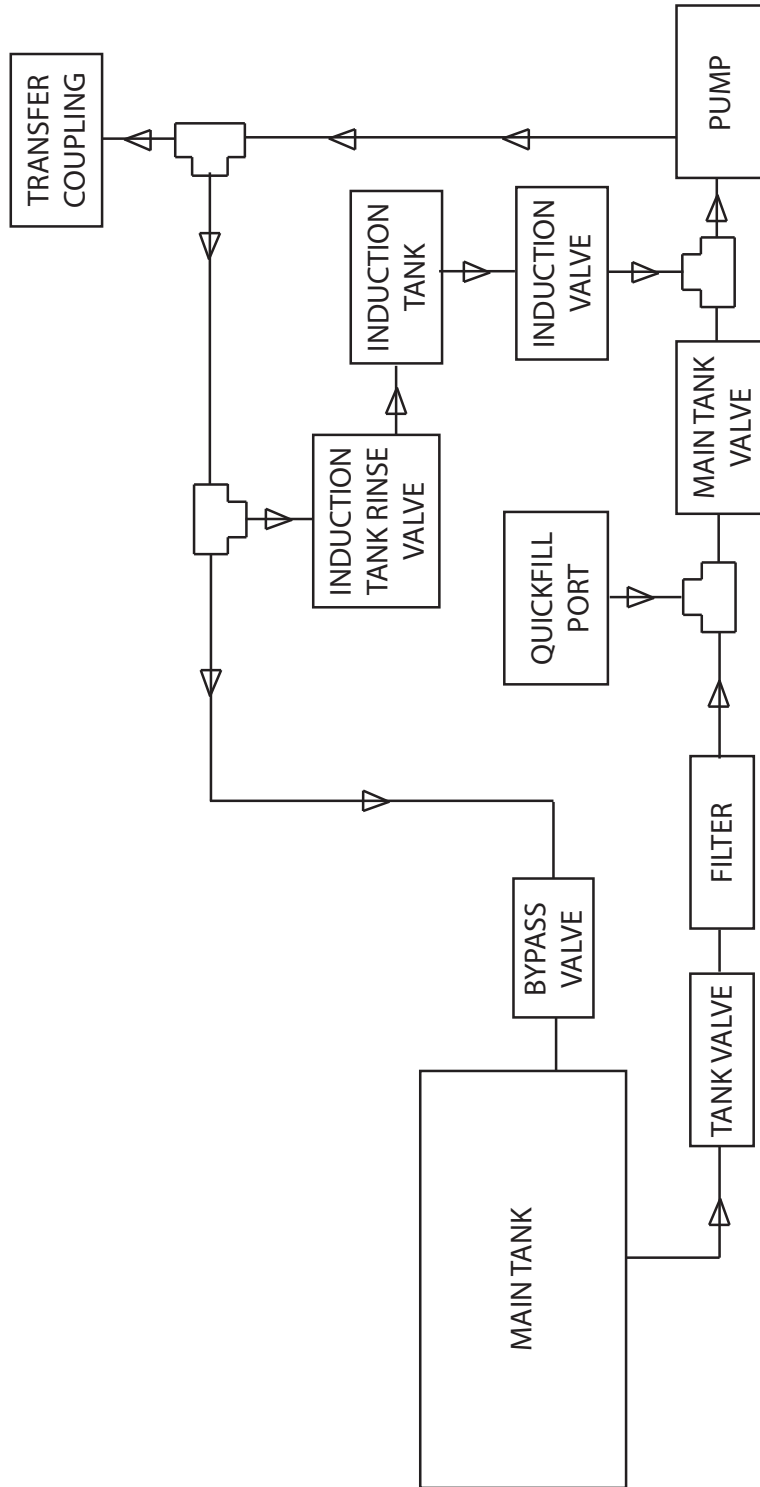

Figure 1: Plumbing Diagram

Maintenance and Adjustments

Maintenance Schedules

-Information concerning periodic maintenance tasks and the recommended frequency.

Frequency	Maintenance Tasks
Every Use	Check for broken or stressed parts
	Check for leaks (Tighten hose clamps and replace hoses as necessary)
	Check for loose connections (hardware)
	Flush unit of fluids after spraying, before storing unit
Every Season	Suction Line strainer: should be taken out and rinsed.
	Winterize the unit when the temperature falls below 30 degrees F
	Grease fittings on axle equalizers (see Figure 2).
	Check condition of brakes for wear.
	Check condition of suspension for wear or stress.
	Check tire air pressure.
	Check condition of tires for wear or cracks.
Check and lug nuts on wheels and tighten as needed.	
Refer to Owner's Manuals	Pumps: Refer to your Pump's Owner's Manual for service intervals and details
	Engine: Refer to your Engine's Owner's Manual for service intervals and details

Maintenance Procedures

Every Use

- Perform a visual and physical inspection for any worn parts, loose bolts, damaged hoses, or other visible problems. Make all necessary repairs before spraying. Also, grease the unit's grease points with general purpose lithium grease if needed. To order parts or receive technical help, please contact your local CropCare® dealer.
- After each use, ensure that the unit's tank and pump are thoroughly rinsed. This can be done by rinsing the unit's tank and running the clean water through the unit's pump until the system is completely rinsed out. All rinsate must be sprayed on the field as recommended by the chemical manufacturer. Excess water can be drained by removing the bowl of the in-line filter located below the tank.

Every Season

- The suction line filter (located below the tank) should have the screen taken out and rinsed.
- NOTE: Follow chemical manufacturers guidelines for proper cleaning of the strainers.
- NOTE: Be careful not to lose the gasket in the filter bowl (Figure 1). A missing gasket will cause the strainer to leak.
- The winterization process should be undertaken before freezing conditions and/or after each season of use. See the Winterizing The Unit section (page 18) for details.

Maintenance and Adjustments

Every Season (Continued)

- Grease fittings on axle equalize bolts (Figure 2).
- Check tightness of lug nuts on wheels.
- Check tire pressure.
- Check condition of tires for wear or cracking.
- Check the condition of brakes for wear.
- Check condition of leaf springs and other suspension parts for wear or stress.

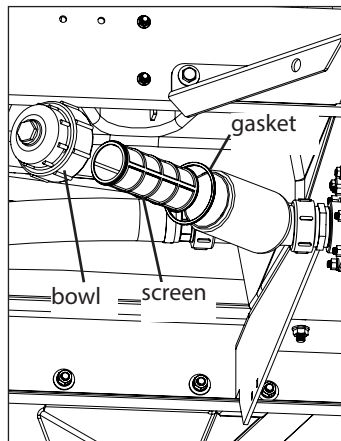

Figure 1: Suction Line Strainer

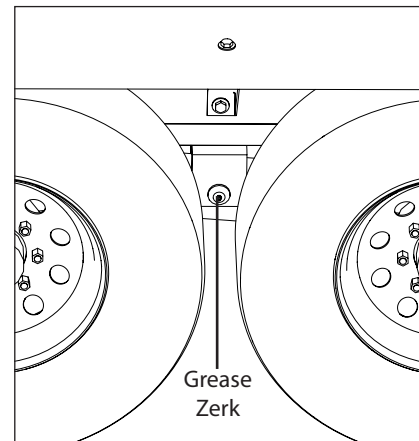

Figure 2: Grease Location on Axle

Preparing the Unit for Winterizing

It is essential that you winterize your unit to avoid damage and to allow for optimal performance. The winterization process should be undertaken before freezing conditions and/or after each season of use. Failure to winterize your unit will void the manufacturer's warranty.

1. Verify that the unit's plumbing system has been rinsed thoroughly and rinsate has been disposed of according to the chemical manufacturer's recommendations.
2. Drain any remaining water from the unit's plumbing system by opening the suction line valve (Figure 2). Then remove the drain cap from the suction filter and capture all fluid in a container. When system is drained, ensure that the rubber gasket is in place and replace drain cap onto suction filter. Dispose of liquid according to the chemical manufacturer's recommendations.

Winterizing the Unit

1. Pour 12 gallons of nontoxic RV antifreeze (propylene glycol) into the unit tank.
2. **IMPORTANT:** Do not use standard automotive antifreeze (ethylene glycol). It is toxic to humans and animals and causes a disposal hazard.
3. **IMPORTANT:** To prevent damage to the tank, open the sealed main tank lid when pumping fluid into or out of the tank.
4. If equipped, open the bypass valve (Figure 1) at the tank.
5. Start the engine and operate at moderate engine speed to engage the unit pump. **IMPORTANT:** Make sure that the pump body is full of liquid before starting the engine.
6. Open the valve on the transfer line until RV antifreeze is observed (if equipped with optional rear watering bar,

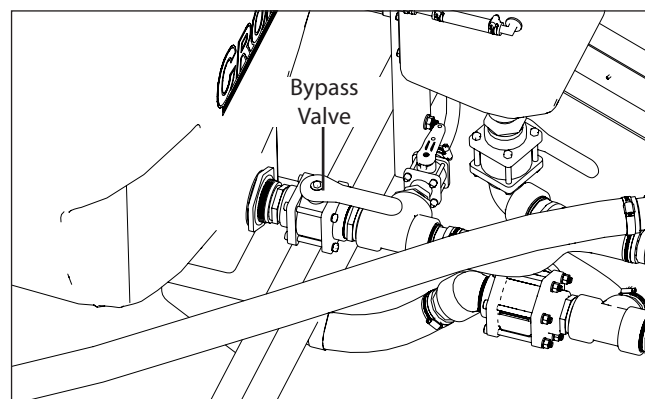

Figure 1: Bypass Valve

Maintenance and Adjustments

Winterizing the Unit (Continued)

run fluid through the line until RV antifreeze is observed spraying from the tips), or until tank is empty.

7. If equipped with chemical induction, pour 1 gallon of RV antifreeze into the chemical induction tank and draw it through the pump (See the Operating the Chemical Induction System, page 11).
8. Shut off the engine to disengage pump. Close the suction line valve, and drain the pump body.
9. Prepare engine for storage. (See engine owner's manual for winterizing or storage details.)
10. Store the unit in a dry location, out of the elements and away from human or animal activity.
11. When operating the unit for the first time following winterization, flush the unit with fresh water to remove the RV antifreeze from the system and thoroughly inspect the unit for leaks or any signs of damage as a result of freezing. (IMPORTANT: Make sure that the pump body is full of liquid before starting the engine.)

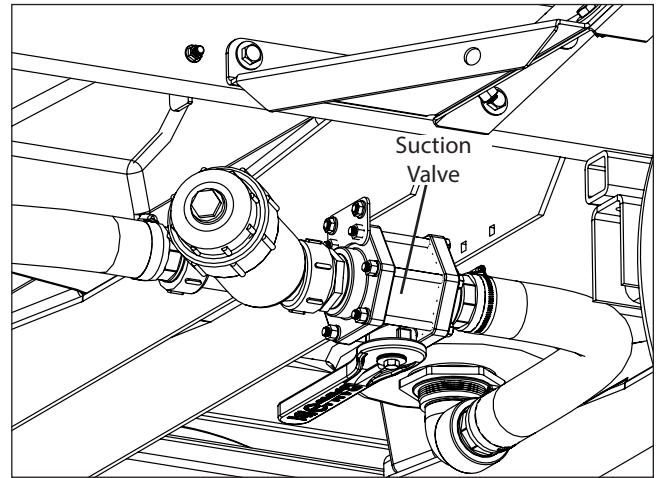

Figure 2: Suction Line Valve

IMPORTANT: Do not, under any circumstances, run any petroleum based substance (such as diesel fuel) through the unit. This will cause damage to unit components and will void the manufacturer's warranty.

Maintenance and Adjustments

Junction Box, Electric Brake Battery Case/Tester & Breakaway Switch

The Wiring Junction box, the Electric Brake Battery/Tester case, and Breakaway Switch are located on the frame rail on the driver's side of the unit (Figures 1 and 3).

NOTE: To test the electric brake system battery, press the button (a) on the case (Figure 2), and note which light turns on. This will indicate the status of the battery, and whether it needs to be charged.

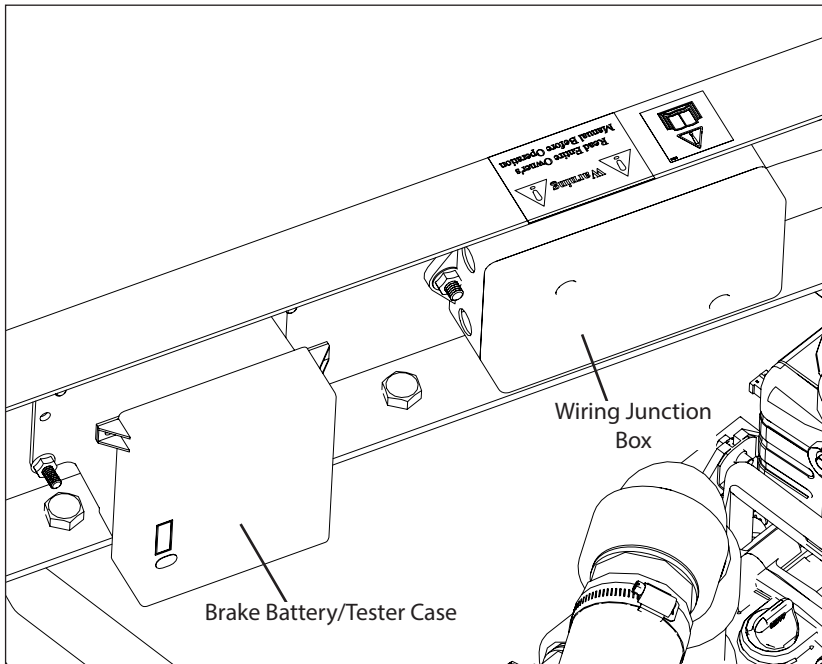

Figure 1: Junction Box and Brake Battery/Tester Case

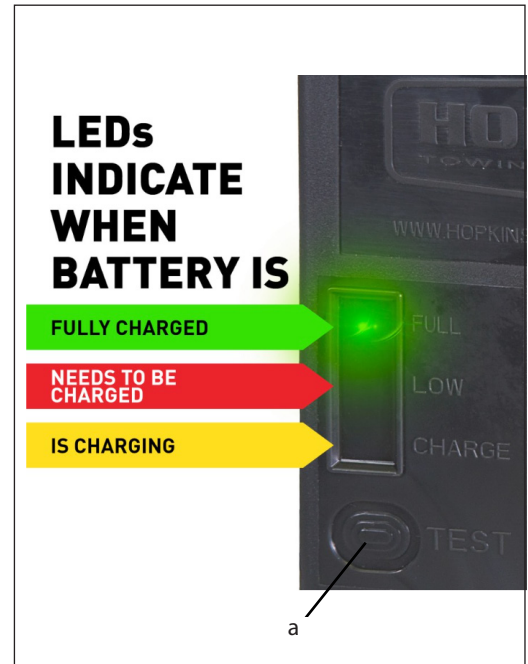

Figure 2: Brake Battery Testing

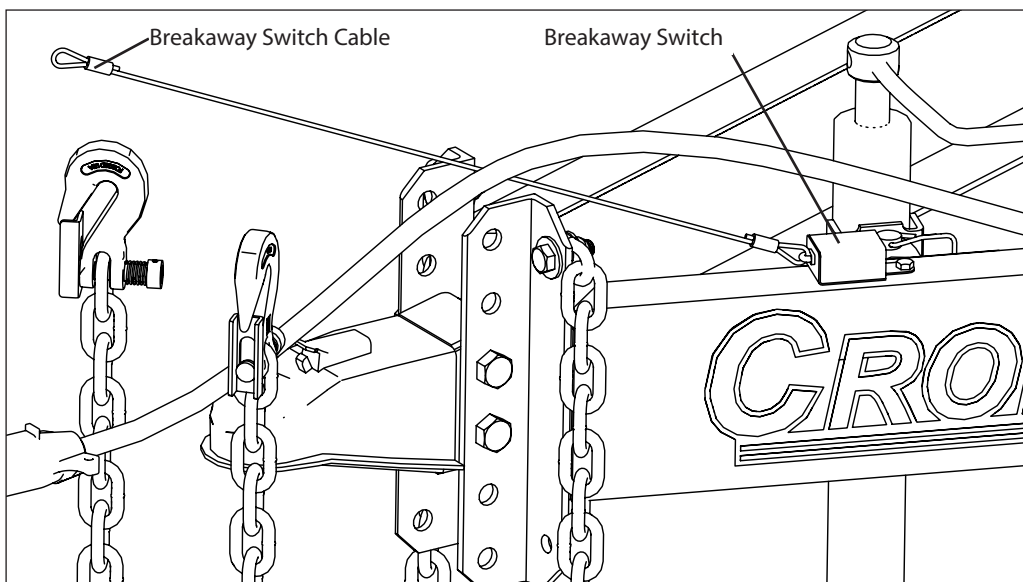

Figure 3: Breakaway Switch

Maintenance and Adjustments

Wiring Diagram

This unit comes equipped with a wiring harness with a 7-way RV plug and wiring junction box.

NOTE: Shown equipped with optional DOT lighting.

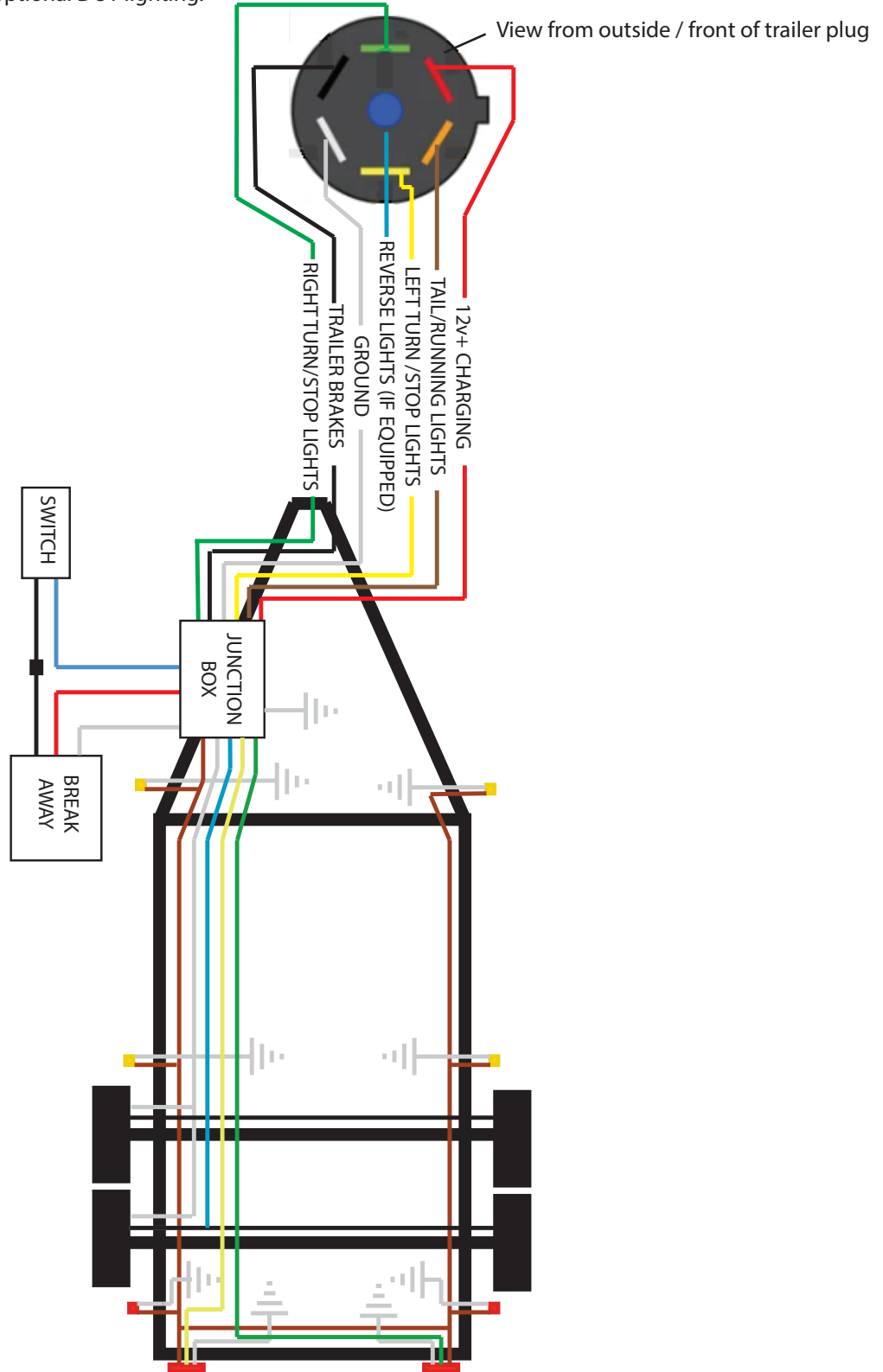

Maintenance and Adjustments

Wiring

This unit comes equipped with a wiring harness with a 7-way RV plug and wiring junction box. Use the views and tables to troubleshoot any electrical problems that may occur with your unit.

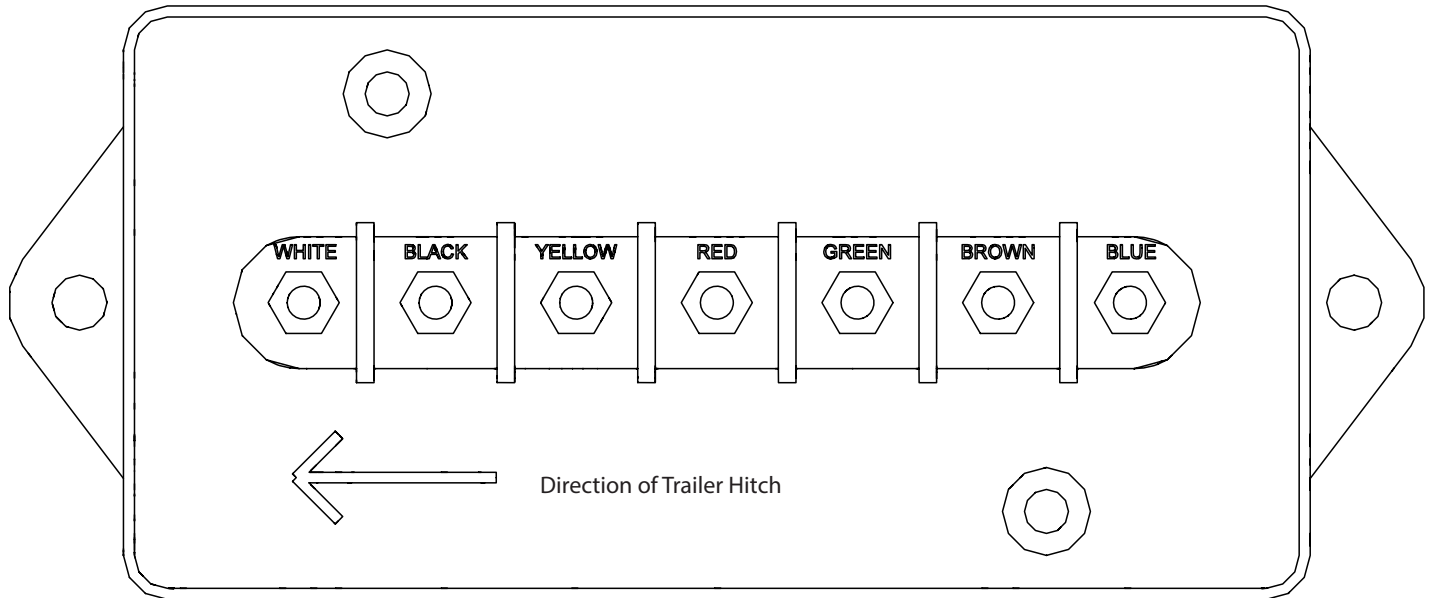

Figure 1: Wiring Junction Box Terminals

Function	Wire Color	Junction Box Terminal	Trailer Plug Terminal
--	--	Black	--
Axle Brake	Blue	Blue	--
Axle Brake	White	White	--
Battery (Brakes)	Black	Red	--
Battery (Brakes)	White	White	--
Breakaway Switch	Blue	Blue	--
Left Light	Brown	Brown	--
Left Light	Yellow	Yellow	--
Right Light	Brown	Brown	--
Right Light	Green	Green	--
Trailer Plug (12 V+)	Red	Red	4
Trailer Plug (Brakes)	Black	Blue	2
Trailer Plug (Ground)	White	White	1
Trailer Plug (Left Turn / Brake Light)	Yellow	Yellow	5
Trailer Plug (Right Turn / Brake Light)	Green	Green	6
Trailer Plug (Tail / Running Lights)	Brown	Brown	3

Figure 2: Wiring Junction Box Terminal Table

Maintenance and Adjustments

Maintenance Materials

-Specifications, including quantities / capabilities for normal maintenance materials, such as:

1. 1-2 gallons of RV nontoxic antifreeze (See "Winterizing The Unit" section)
2. General-purpose lithium grease (See "Maintenance Procedures" section)

Adjustments

-This unit has the following adjustments.

- The front hitch (a) can be unbolted and moved to a different height settings to better fit the tow vehicle (Figure 1).

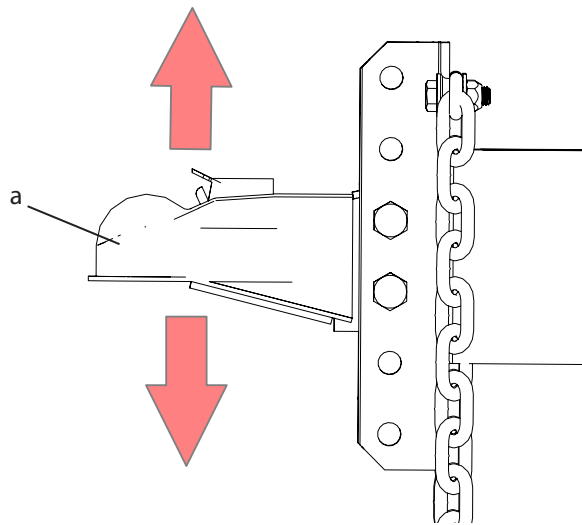

Figure 1: Hitch Adjustment

Maintenance and Adjustments

Storage

The following procedures are to be taken to prepare the unit for storage.

- Before storage, ensure that the unit's tank and pump are completely rinsed out. This can be done by rinsing the unit's tank and running the clean water through the unit's pump until the system is completely rinsed out. All rinsate must be emptied on the field as recommended by the chemical manufacturer. Excess water can be drained by removing the bowl of the in-line filter located below the tank.
- See Engine Owner's Manual for long term storage instructions for the gas powered engine.
- Store the unit in a safe, dry location away from the elements and human and animal activity.

NOTE: If there will be freezing conditions during storage the unit needs to be winterized (See "Winterizing The Unit" for details).

Specifications

General Specifications

Tank Capacity.....	1010 Gallons
Hitch.....	Ball Coupler (2-5/16") / Optional Pintle Ring (2-1/2" ID)
GVWR.....	13,500 lbs
Overall Dimensions	
Height.....	81 inches
Width	89 inches
Length	228 inches (19 ft)
Weight (Empty)	2,160 lbs

Transportation

Transportation

- When transporting the unit on public roads, always follow state and local regulations regarding safety and transportation requirements. Use the necessary lights and slow moving vehicle (SMV) emblems.
- Never exceed the tractor, or alternative vehicle's load and/or tow ratings.
- Check the unit's braking system to ensure proper function (See Junction Box, Electric Brake Battery Case/Tester & Breakaway Switch, page 19).
- Check all lighting before traveling.
- Make sure SMV sign is not blocked or bent.
- Connect safety chains and trailer breakaway cable to towing vehicle.

CropCare® Limited Warranty

Warranty Coverage

CropCare® hereby provides a Limited Two (2) Year Warranty on the Products manufactured by CropCare® that such Products shall be free from manufacturer's defects in any of the Product's components in the 24 month period following the original date of purchase from the authorized dealer (the "Warranty Period"). CROPCARE® HEREBY EXCLUDES AND DISCLAIMS ANY AND ALL OTHER WARRANTIES, STATUTORY, EXPRESS OR IMPLIED, INCLUDING WITHOUT LIMITATION ANY IMPLIED WARRANTY OF MERCHANTABILITY OR FITNESS FOR ANY PARTICULAR PURPOSE AND ANY WARRANTY ARISING FROM USAGE OF TRADE OR COURSE OF DEALING. Defective components will be repaired or replaced at the discretion of the manufacturer. It is the responsibility of the purchaser to return warranted components to the manufacturer. This Product Warranty is limited to the repair or replacement of Product components only. CROPCARE® IS NOT TO BE HELD LIABLE FOR INCIDENTAL OR CONSEQUENTIAL DAMAGES OF ANY KIND. This Product Warranty covers the purchaser of this Product and any other owners who own it during Warranty Period.

To retain the Product Warranty, the Product must be operated and maintained as set forth by its owner's manual. For warranty service, please have a copy of the purchase invoice available.

Warranty is Void if:

1. The Product has been subjected to, in the opinion of CropCare®, negligent handling, misuse, an accident or if the instructions in the owner's manual were not completely followed.
2. The Product's components have been altered in any manner or repairs have taken place with unapproved parts.
3. The Product and its components were subject to freezing or freezing conditions. The Product must have been winterized as per the maintenance instructions to retain the Product Warranty.
4. A non-compatible chemical was used and/or if the Product operator failed to rinse all chemical residue out of the Product's components after use.
5. A petroleum-based, oil-based, or flammable product was used and caused damage to the pump, tank, hoses, or any other component.

Getting Warranty Service

All Product Warranty claims must be made through an authorized CropCare® dealer. All warranty claims must be submitted with an invoice or a proof of purchase that denotes the purchase date and place of purchase. If you have any questions or comments concerning this warranty, please contact an authorized CropCare® dealer.

Ordering Parts

Please contact your authorized CropCare® dealer to order replacement parts for your product.

Parts List & Breakdowns

Parts lists are available on www.CropCareEquipment.com/equipment-build-lists.php. Breakdowns can be acquired through a dealer.

CROPCARE

by PBZ[®]

Manufactured by PBZ LLC
A Paul B Zimmerman Inc. Company
www.CropCareEquipment.com